

2 MECHANICAL EQUIPMENT

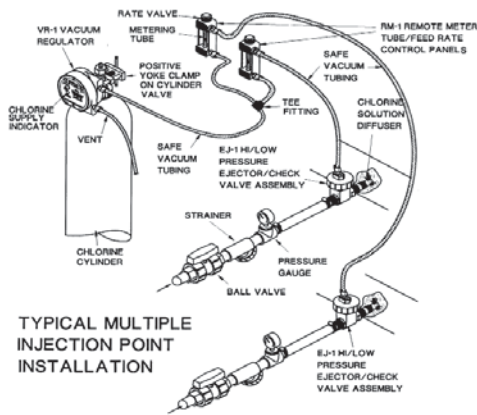

Additional Feed Point

Item No.	Description	Price
12 20 03	Additional Feed Point (1 remote meter and 1 ejector)	\$1417.00

Specify 4, 10, 25, 50 or 100 lbs/day feed capacity.

Superior Parts

12 21 50	Repair Parts Kit VRM-1	\$547.76
12 21 51	Repair Parts Kit VR-16	\$307.28
12 21 52	Repair Parts Kit RM-1	\$130.26
12 21 53	Repair Parts Kit EJ-1	\$255.51
12 21 54	Repair Parts Kit SPR-1	\$133.60
12 21 55	Ejector EJ-1 Complete	\$710.10
12 21 56	Remote Meter RM-1 Complete	\$765.45
12 21 58	Metering Tube Assembly 10lb/day	MT-130 \$425.85
12 21 59	Metering Tube Assembly 25lb/day	MT-140 \$412.49
12 21 60	Metering Tube Assembly 50lb/day	MT-150 \$412.49
12 21 61	Metering Tube Assembly 100lb/day	MT-160 \$412.49
12 21 62	Nozzle EJ-130 #5	\$420.84
12 21 63	Tailway EJ-150 (Diffuser)	\$104.38
12 21 64	Tubing fitting TU-150 for 3/8 OD Tube x 1/4 NPT	\$27.97
12 21 65	Tubing tee 3/8 x 3/8 x 3/8	\$32.65
12 21 66	VR-16 Latching vacuum regulator	\$1841.40
12 21 67	Pressure relief/vent valve SPR-1	\$438.75
12 21 68	GK-111 Metering Tube Gasket	\$33.50
12 21 69	GK112 Metering tube gasket	\$33.50
12 19 53	OR-114 O-ring	\$17.80
12 19 54	CV-150 Check Valve	\$76.40
12 19 55	CV-106 Spring	\$157.34
12 19 56	CV-110 Pressure Check Valve Seat	\$175.10
12 19 57	CV-104 Diaphragm	\$49.10
12 19 58	CV-111 Inlet Valve Body	\$199.31

Factory Authorized Repair Centre for Superior Chlorinators

Chlorinators sent to us will be repaired and tested to factory specs and returned, normally within a week



Two Cylinder Scale

- Low fiberglass base for corrosive resistance and ease of use
- Mechanical scale with 2 readouts and 2 tare adjustments so scale weighs only cylinder contents (150 lbs/gas per cylinder)
- Safety chains for each cylinder

Item No.	Description	Price
12 20 04	2 Cylinder scale Mechanical #2330	\$3185.00
12 20 05	2 Cylinder scale Digital #2350	\$3950.00

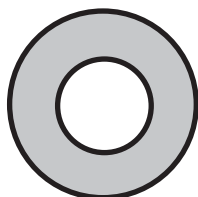

Lead washers for Chlorine Gas Cylinders

12 21 90	Lead washer for chlorine gas cylinders	\$2.10 ea.
12 21 91	Lead Washers Roll of 50	\$85.95

Shown actual size

Parts Diagram for Superior Chlorinators

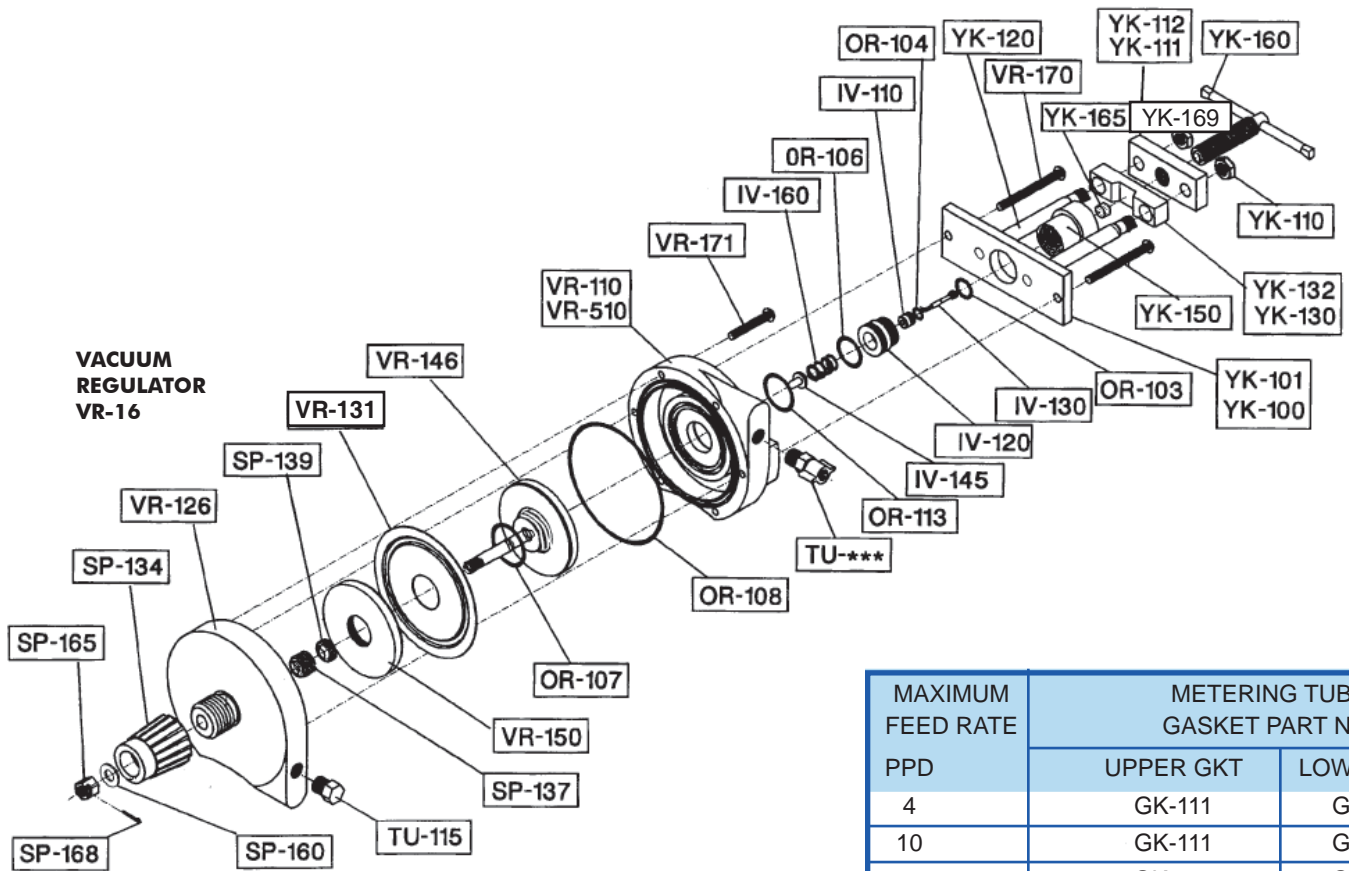

MAXIMUM FEED RATE PPD	METERING TUBE GASKET PART NO.	
	UPPER GKT	LOWER GSK
4	GK-111	GK-111
10	GK-111	GK-111
25	GK-112	GK-111
50	GK-112	GK-111
100	GK-112	GK-111

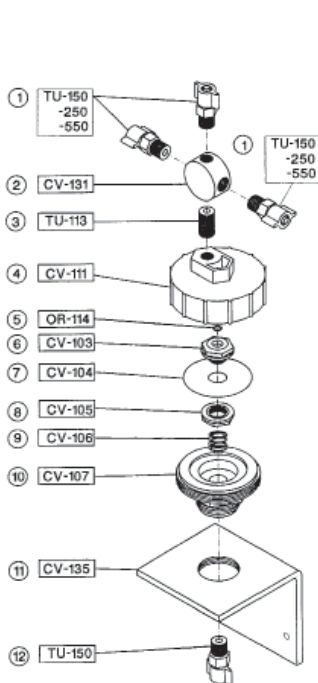

PRESSURE RELIEF/ VENT VALVE

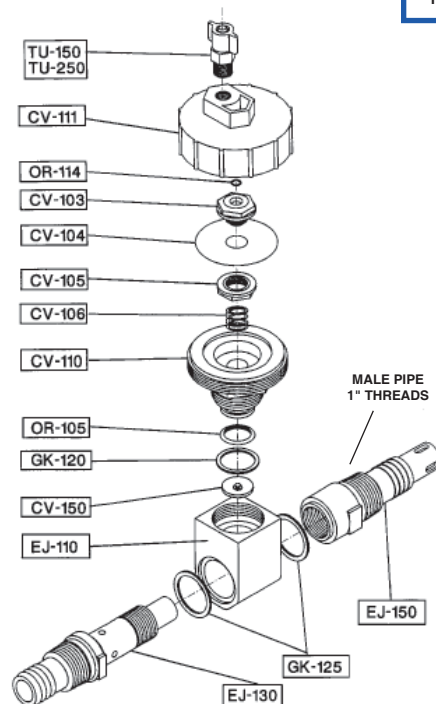

EJECTOR

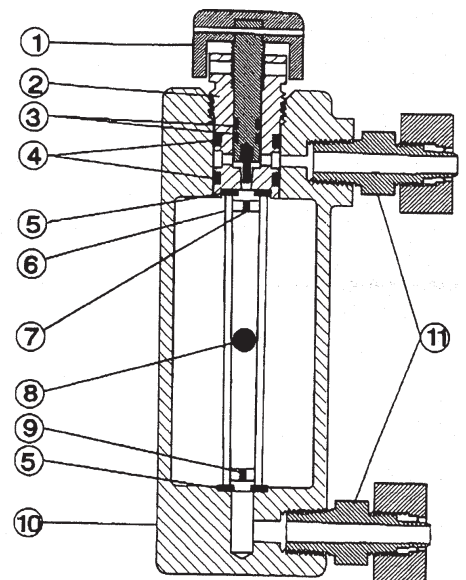

REMOTE METER